

GASES

- Gases differ from the other two phases of matter in many ways:
 - They have very low viscosity (resistance to flow), so they flow from one place to another very easily.
 - They will take the volume of their container. In other words, gas volumes are variable.
 - They are the least dense of all three phases.
 - Most gases are transparent, and many are invisible.
 - Gases show a much larger change of volume on heating or cooling than the other phases.
- Gases react to changes in temperature and pressure in a very similar way. This reaction often does not depend on what the gas is actually made of.

↙ thermal expansion!

KINETIC THEORY

- is a way to explain the behavior of gases.
 - views the properties of gases as arising from them being molecules in motion.
-

- Pressure: force per unit area. Units: Pascal, bar, mm Hg, in Hg, atm, etc.

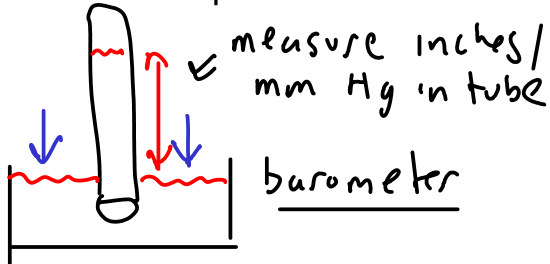

$$760 \text{ mm Hg} = 1 \text{ atm}$$

- According to kinetic theory, pressure is caused by collisions of gas molecules with each other and the walls of the container the gas is in.

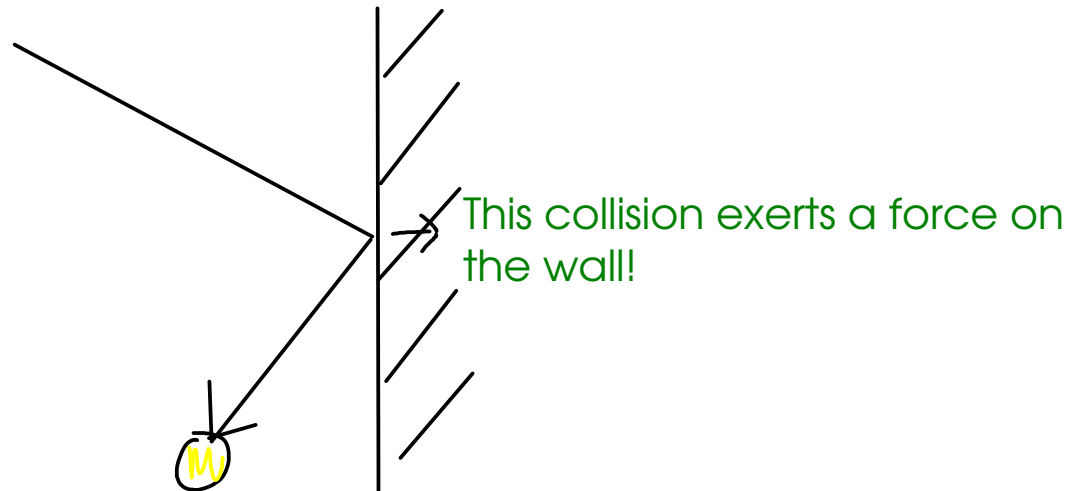

201 - Temperature:

- a measure of the average kinetic energy of the molecules of the gas

$$E_k = \frac{1}{2} m v^2$$

velocity
mass

- The faster the gas molecules move, the higher the temperature!
- The temperature scales used when working with gases are ABSOLUTE scales.
 - ABSOLUTE: scales which have no values less than zero.
 - KELVIN: metric absolute temperature scale.

Quick comparison of temperature scales!

$$K = 273.15 + ^\circ C$$

212	100	373	Water boils
77	25	298	Room temperature
32	0	273	Water freezes
-460	-273	0	Absolute zero!
$^{\circ}F$	$^{\circ}C$	K	

THE KINETIC PICTURE OF GASES

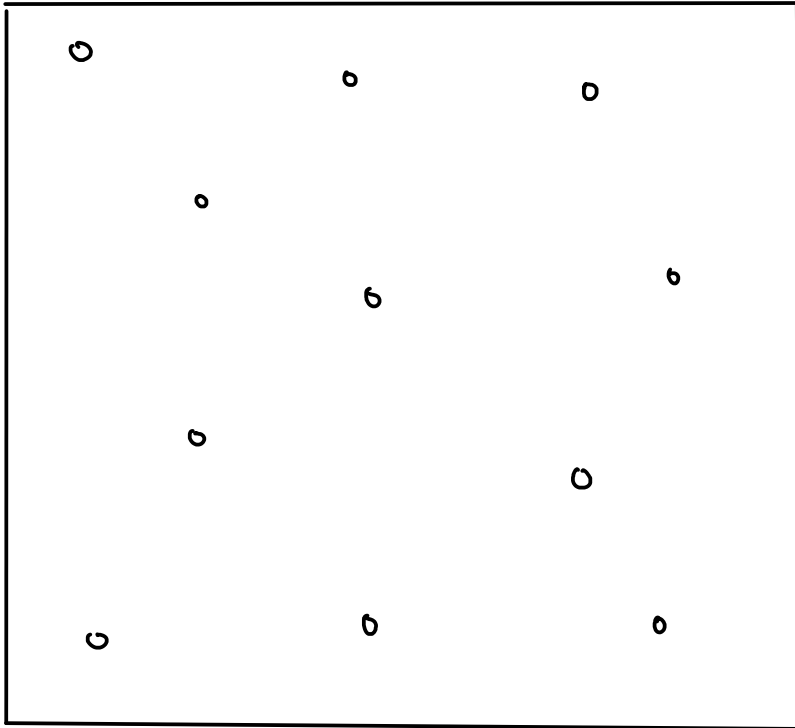

① Gas molecules are small compared to the space between the gas molecules!

LOW DENSITY!

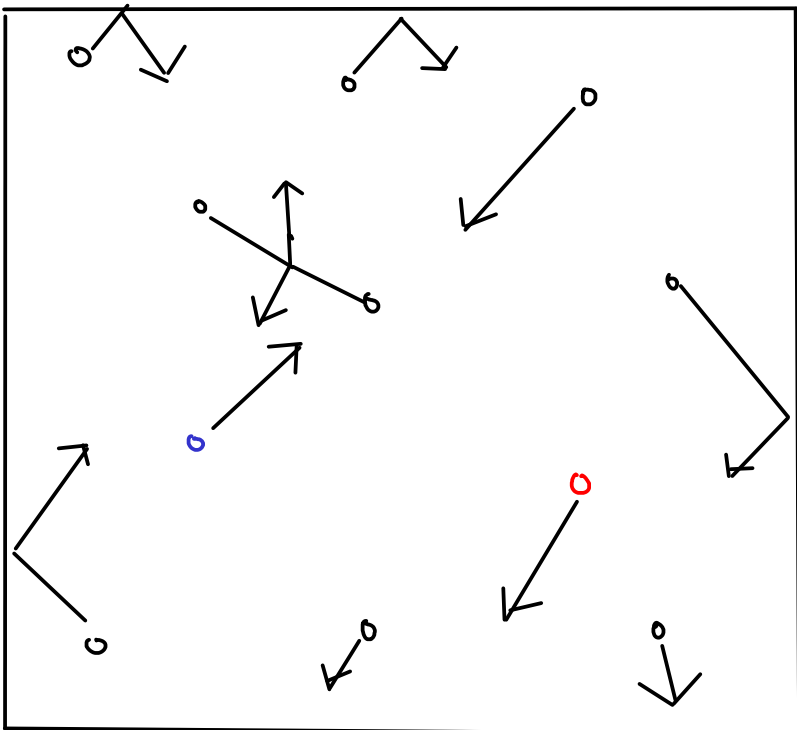

②

Gas molecules are constantly in motion. They move in straight lines in random directions and with various speeds.

③

Attractive and repulsive forces between gas molecules are so small that they can be neglected except in a collision.

- Each gas molecule behaves independently of the others.

④

Collisions between gas molecules and each other or the walls are ELASTIC.

⑤ The average kinetic energy of gas molecules is proportional to the absolute temperature.

How does this picture explain the properties of gases?

- Gases expanding to fill their container? Agrees with kinetic picture, since gas molecules are independent
- Thermal expansion of gas at constant pressure? Agrees, because the container has to EXPAND to keep the pressure (from collisions) constant when the gas molecules move faster.
- Pressure increases with temperature at constant volume: Agrees, because the number and force of collisions increases with molecular speed.

GAS LAWS

- were derived by experiment long before kinetic theory, but agree with the kinetic picture!

Boyle's Law: $PV = \text{constant}$] True at constant temperature

$$P_1 V_1 = \text{constant} \qquad P_2 V_2 = \text{constant}$$

$$\rightarrow \boxed{P_1 V_1 = P_2 V_2} \text{ True at constant temperature}$$

Charles's Law:

$$\frac{V}{T} = \text{constant} \text{] True at constant pressure, and using ABSOLUTE temperature}$$

$$\rightarrow \boxed{\frac{V_1}{T_1} = \frac{V_2}{T_2}} \text{ True at constant pressure, and using ABSOLUTE temperature}$$

$$\frac{PV}{T} = \text{constant}$$

Must use ABSOLUTE temperature units!

$$\frac{P_1 V_1}{T_1} = \frac{P_2 V_2}{T_2}$$

Must use ABSOLUTE temperature units!

↑ amount (moles) of gas must be constant!

Avogadro's law:

- a mole of any gas at the same conditions has the same volume.

1 mol gas molecules @ 0°C and 1 atm
 volume = 22.4 L

"STP"
 Standard
 Temperature
 and
 Pressure

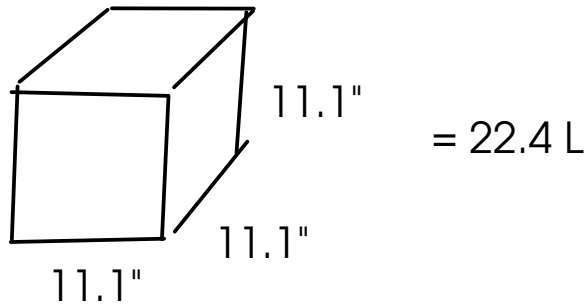

Ideal gas law:

$$\frac{PV}{T} = \text{constant}$$

... but this constant actually depends on the amount of gas!

$$= n \times "R"$$

The ideal gas constant.

$$0.08206 \frac{\text{L} \cdot \text{atm}}{\text{mol} \cdot \text{K}}$$

... combining these together ...

$$\frac{PV}{T} = nR$$

↓

$$PV = nRT$$

P = pressure atm

V = volume L

T = ABSOLUTE temperature K

R = ideal gas constant

n = number of moles of gas molecules